

Surname
Other Names

Centre Number

Candidate Number
0



GCSE

4370/03

**MATHEMATICS – LINEAR
PAPER 1
FOUNDATION TIER**

A.M. TUESDAY, 11 June 2013

$1\frac{3}{4}$ hours

<p>CALCULATORS ARE NOT TO BE USED FOR THIS PAPER</p>

ADDITIONAL MATERIALS

A ruler, a protractor and a pair of compasses may be required.

INSTRUCTIONS TO CANDIDATES

Use black ink or black ball-point pen. Do not use gel pen or correction fluid.

Write your name, centre number and candidate number in the spaces at the top of this page.

Answer **all** the questions in the spaces provided.

If you run out of space, use the continuation page at the back of the booklet, taking care to number the question(s) correctly.

Take π as 3.14.

INFORMATION FOR CANDIDATES

You should give details of your method of solution when appropriate.

Unless stated, diagrams are not drawn to scale.

Scale drawing solutions will not be acceptable where you are asked to calculate.

The number of marks is given in brackets at the end of each question or part-question.

You are reminded that assessment will take into account the quality of written communication (including mathematical communication) used in your answer to question 15.

For Examiner's use only		
Question	Maximum Mark	Mark Awarded
1	11	
2	8	
3	4	
4	7	
5	6	
6	3	
7	3	
8	8	
9	4	
10	4	
11	8	
12	3	
13	5	
14	7	
15	9	
16	4	
17	6	
TOTAL MARK		

4370
03/0001



J U N 1 3 4 3 7 0 0 3 0 1

Formula List

Area of trapezium = $\frac{1}{2}(a + b)h$

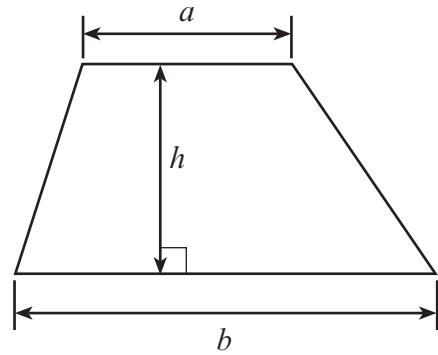

Volume of prism = area of cross-section \times length

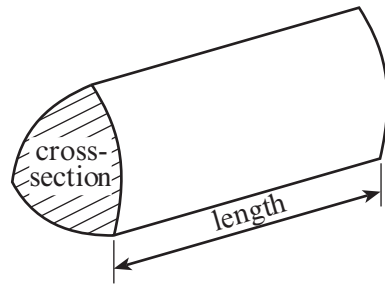

1. (a) (i) Write down, in figures, the number thirty two thousand and fifty six. [1]

.....
(ii) Write down, in words, the number 10 102. [1]

.....

(b) Using only the numbers in the following list,

44 48 13 12 36 23 41

write down

(i) two numbers that have a sum of 67, [1]

.....

(ii) two numbers that have a difference of 29, [1]

.....

(iii) a square number. [1]

.....

(c) Write 6518

(i) correct to the nearest 10, [1]

.....

(ii) correct to the nearest 1000. [1]

.....

(d) Write down all the factors of 18. [2]

.....

.....

(e) Each of the digits 6, 1, 3 and 4 is used once to make a four-digit number.

(i) What is the smallest number that can be made? [1]

.....

(ii) What is the largest **even number** that can be made? [1]

.....



2. (a) Write down the next term in **each** of the following sequences.

(i) 35, 29, 23, 17,

(ii) 12, 16, 21, 27,

.....
 [2]

(b) What is the value of the 8 in the number 78 431?

..... [1]

(c) Write $\frac{3}{4}$ as a decimal

Write 77% as a decimal

Write $\frac{3}{4}$, 77% and 0.73 in ascending order.

.....
 [3]

(d) Showing all your working, find an **estimate** for the value of 98.6×19.2 .

.....

 [2]



3. The formula for finding the value of any term in a sequence is

$$\text{value of the term} = 7 \times \text{number of the term} + 4$$

- (a) Find the **value of the term** when the **number of the term** is 9.

.....

.....

.....

.....

[2]

- (b) Find the **number of the term** when the **value of the term** is 88.

.....

.....

.....

.....

.....

.....

[2]



4. Fifty pupils were asked to choose one sport from Rugby (R), Soccer (S), Hockey (H) or Tennis (T).
Here are the results of the survey.

R	H	R	H	T	S	S	R	H	S
T	R	H	R	S	R	T	H	T	H
S	T	R	S	H	T	R	H	R	H
H	R	S	R	H	S	T	S	R	S
R	S	H	R	T	R	H	H	R	S

- (a) Using the centimetre squared grid on the opposite page, draw a bar chart for the data given.

.....

.....

.....

.....

.....

.....

.....

.....

.....

.....

[6]



For use with question 4

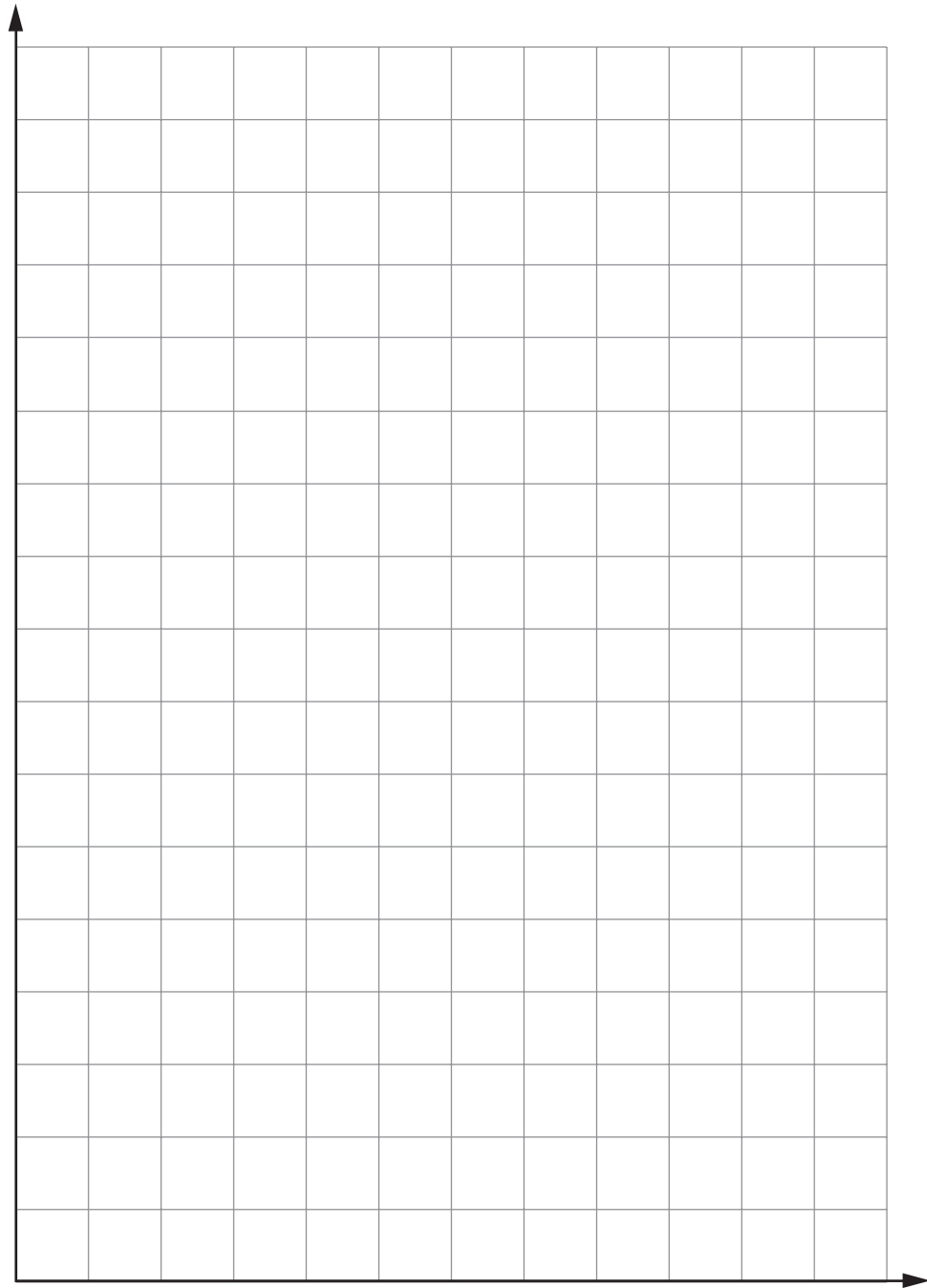

4370
03/0007

(b) Write down the mode.

.....

[1]



5. Three overlapping rectangles, each 8 cm by 3 cm, are placed so as to make the shape shown in the diagram.

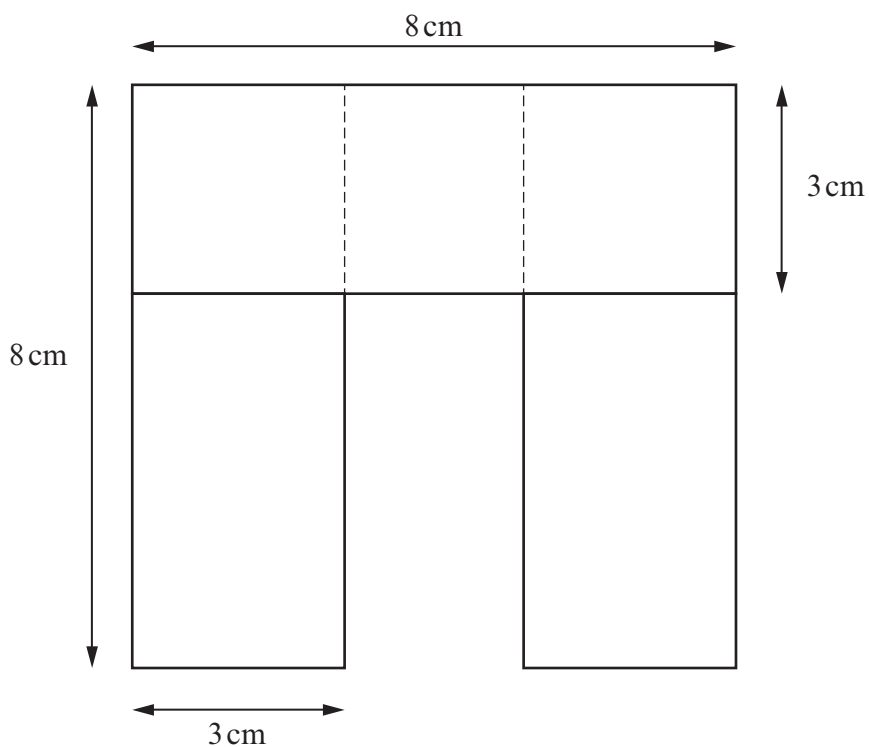

Diagram not drawn to scale

- (a) Calculate the perimeter of the shape.

.....

.....

.....

[3]

- (b) Calculate the area of the shape.
Write down the units of your answer.

.....

.....

.....

.....

[3]



6. (a) Simplify $3x + 4x - x$.

.....
 [1]

- (b) Use the formula $P = 6T + 4H$ to find the value of P when $T = 5$ and $H = 9$.

.....

 [2]

7. On the squared paper below, plot the points $A(6, -5)$, $B(-2, -4)$ and $C(-3, 3)$.

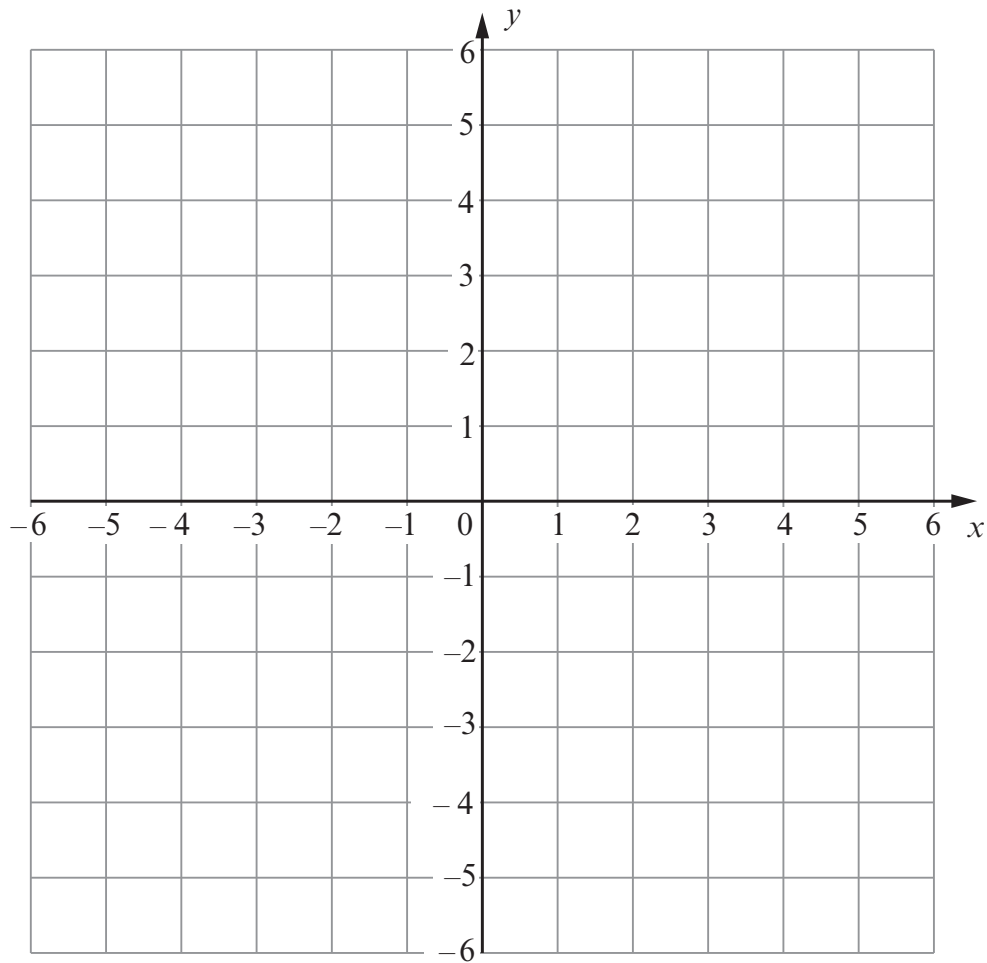

[3]



8. (a) Complete an accurate drawing of triangle ABC , in which $BC = 12\text{ cm}$, $\widehat{ABC} = 54^\circ$ and $BA = 9\text{ cm}$.
The side BC has been drawn for you.

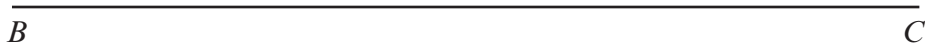

[3]

- (b) Write down the special name given to angles which are greater than 180° , but less than 360° .

.....

[1]



- (c) Two litres of water are poured into an empty rectangular tank of length 25 cm and width 20 cm.
The water completely fills the tank, without it overflowing.
Calculate the depth of the tank.

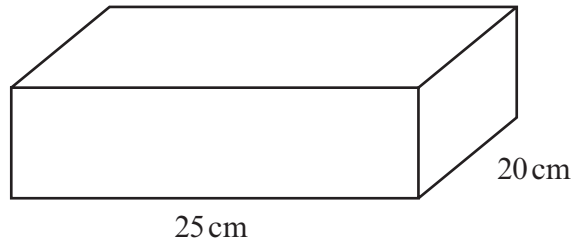

Diagram not drawn to scale

.....

.....

.....

.....

.....

[4]



9. (a) Draw two more shapes so that the completed pattern has rotational symmetry of order 4 about O .

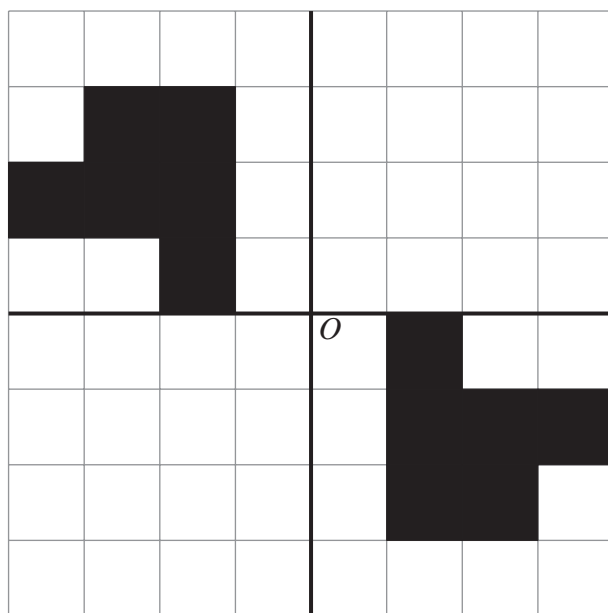

[2]

- (b) Draw all the lines of symmetry on the following two diagrams.

(i)

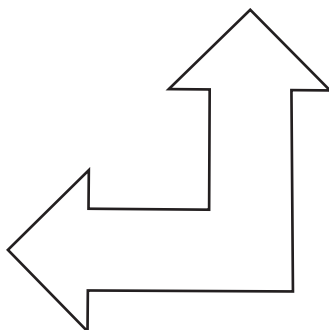

(ii)

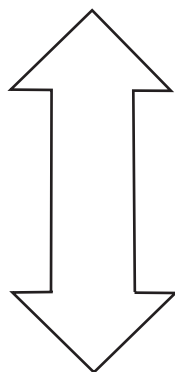

[2]



10. (a) The weight of an object on the planet Mars is different from the object's weight on Earth. The table shows the weight in newtons (N) of three different objects on Earth and on Mars.

Weight on Earth (N)	114	85	24
Weight on Mars (N)	43	32	9

Use the data in the table to draw a conversion graph between weights on Earth and weights on Mars.

Weight on Mars, in N

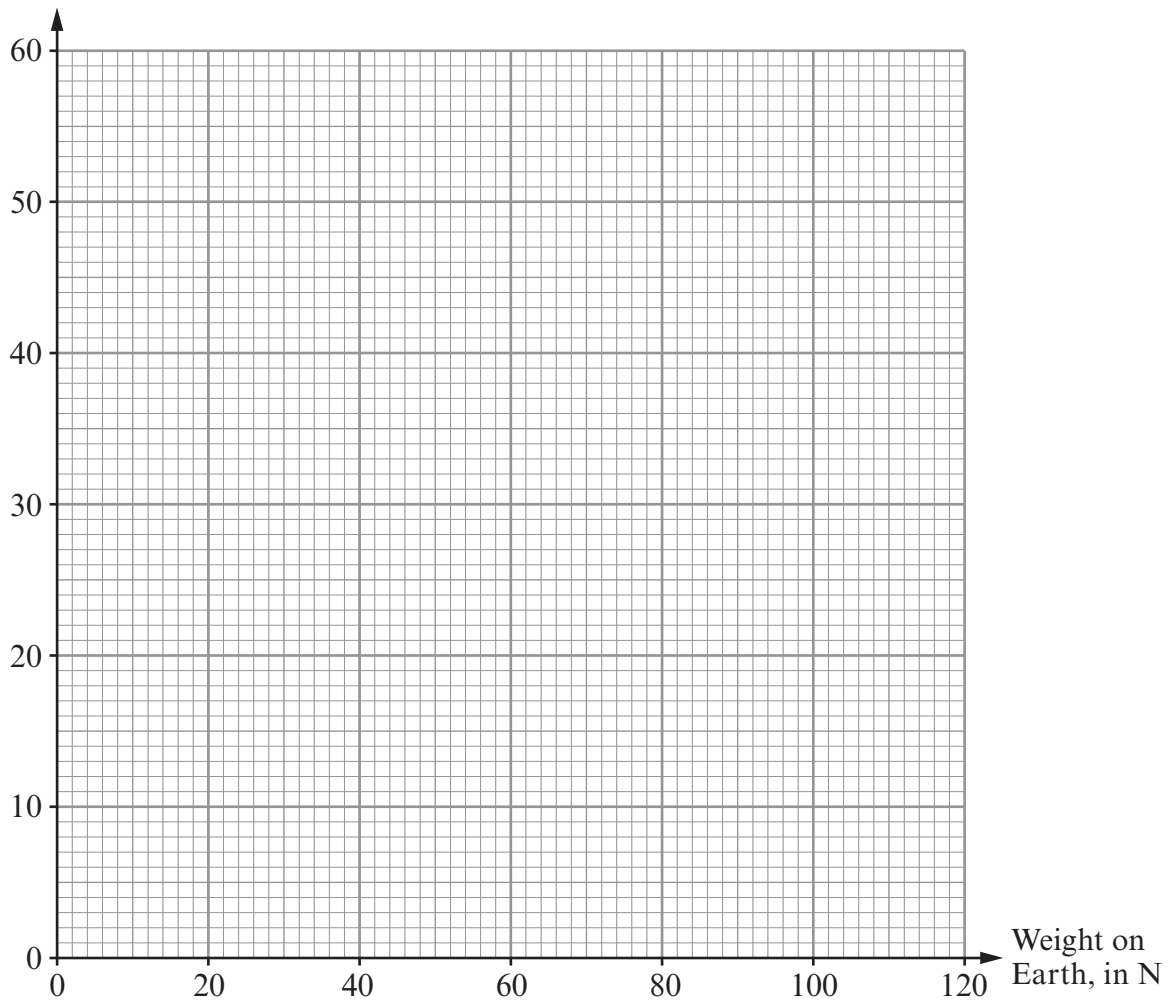

[2]

- (b) A rock weighs 370 N on Mars.
Find an estimate for the weight of this rock on Earth.

.....

.....

.....

[2]



11. In bag A, there are four cards numbered 1, 2, 4 and 5 respectively. In bag B, there are four cards numbered 3, 4, 6 and 7 respectively.

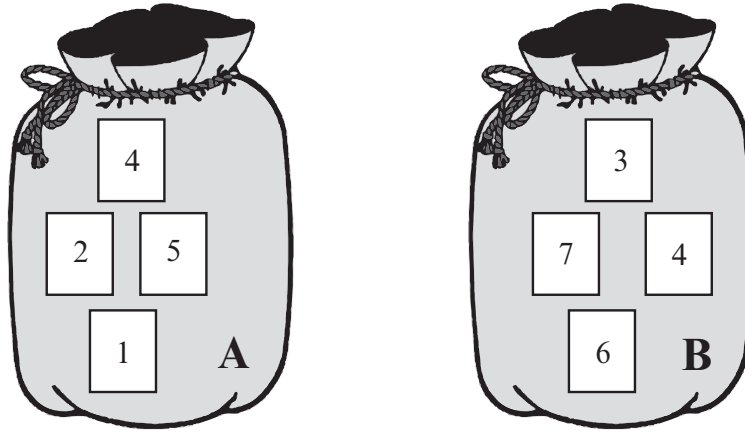

In a game, one card is chosen at random from bag A and one from bag B. The score for the game is the positive difference between these two numbers. For example, if the number on the card from bag A is 1 and the number on the card from bag B is 3, the score is $3 - 1 = 2$.

- (a) Complete the following table to show all the possible scores.

Bag A	5	2	1
	4	1	2
	2	1	4
	1	2	5
		3	4	6	7
		Bag B			

[2]



(b) A player wins a prize by getting a score of 2 or less.

(i) What is the probability of a player winning a prize?

.....
..... [2]

(ii) 80 people each play the game once.
Approximately how many would you expect to win a prize?

.....
..... [2]

(iii) It costs 90p to play the game once. The prize for getting a score of 2 or less is £1.20.
If the 80 people each play the game once, approximately how much profit do you expect the game to make?

.....
.....
.....
.....
.....
.....
.....
.....
.....
..... [2]



12. A bucket when full of water weighs 18 kg.
Half of the water is poured away.
The bucket and water now weigh 11 kg.
What is the weight of the empty bucket?

.....

.....

.....

.....

.....

.....

.....

.....

[3]



13. (a) Find the size of angle x .

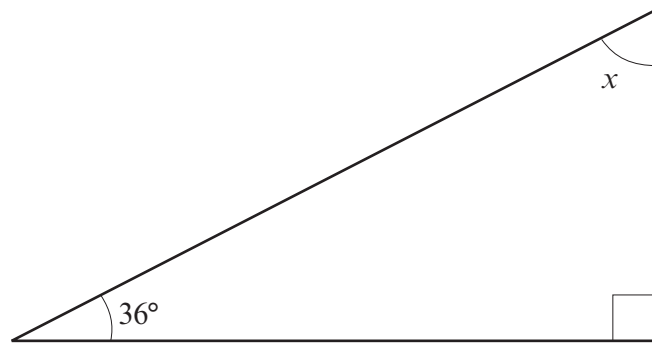

Diagram not drawn to scale

.....

.....

.....

$$x = \text{.....}^\circ$$

[2]

- (b) Find the size of angle y .

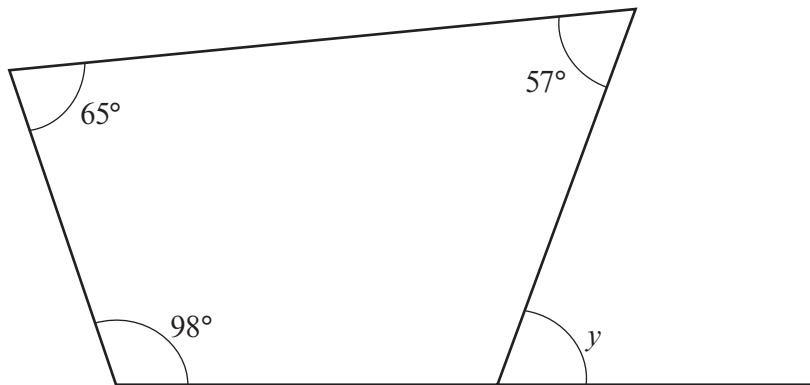

Diagram not drawn to scale

.....

.....

.....

.....

$$y = \text{.....}^\circ$$

[3]



14. Every Friday for 6 weeks, the number of customers entering a sandwich shop and the takings of the shop were recorded. The takings were recorded correct to the nearest £10. The table below shows the results.

Number of customers	104	82	120	64	70	118
Takings, in £	510	420	590	320	340	560

- (a) On the graph paper below, draw a scatter diagram of these results.

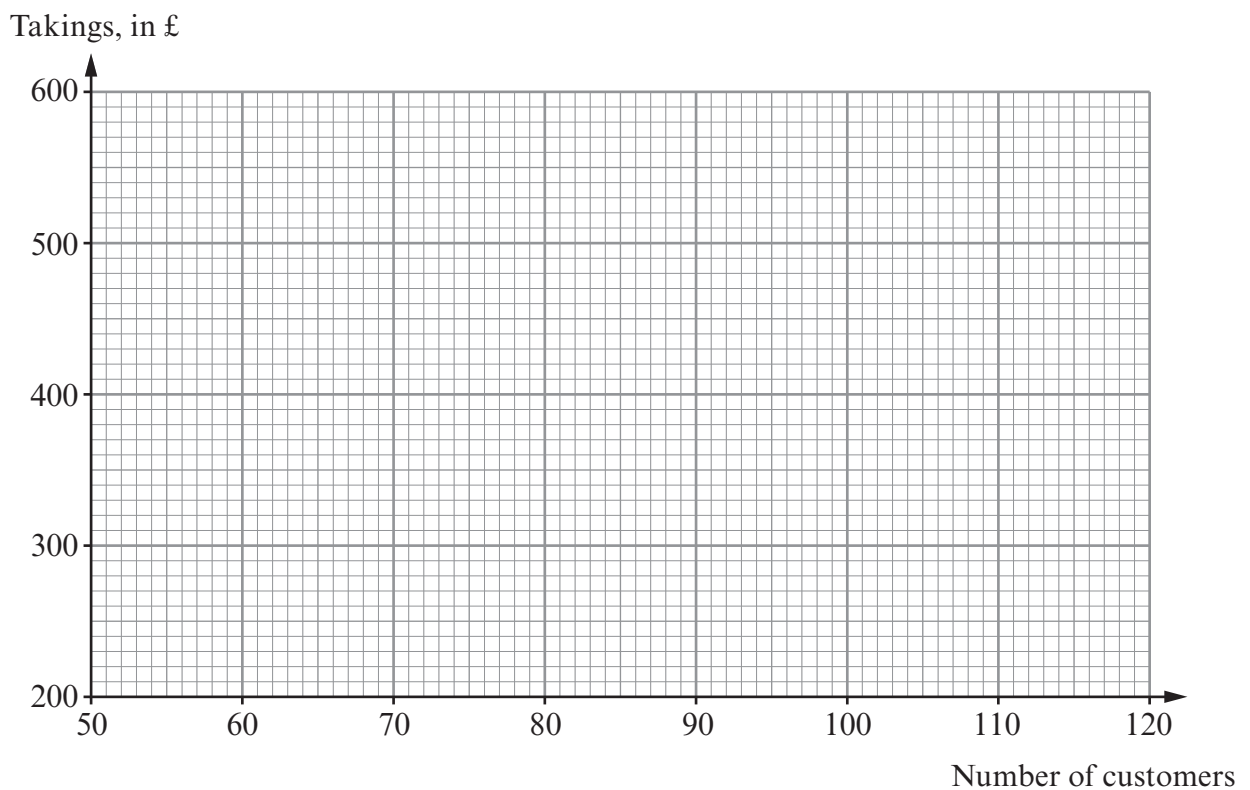

[2]

- (b) Write down the type of correlation that is shown by the scatter diagram.

..... [1]

- (c) Draw, by eye, a line of best fit on your scatter diagram.

[1]

- (d) Estimate the takings for a Friday when there are 90 customers.

..... [1]



(e) Approximately how much does a customer spend, on average, in the sandwich shop on a Friday?

.....

.....

.....

[2]



15. You will be assessed on the quality of your written communication in this question.

Pedro has just moved to live on an island in Europe.
There is a choice of two different water companies.

Manana Water

No Standing Charge

Pay €0.06 per m³ of water used

Channel Water

Standing Charge: €30 every 3 months
+

€0.02 per m³ of water used

Special offer: 20% off your **first** bill

Pedro estimates that he uses 700m³ of water every three months.

He wants to spend as little as possible on water.

Which company should Pedro buy his water from?

You must justify your answer by showing all possible costs.

.....

.....

.....

.....

.....

.....

.....

.....

.....

.....

.....

.....

.....

.....

.....

.....

.....

.....

.....

.....

.....

[9]



16. (a) Express 936 as a product of prime numbers in index form.

.....

.....

.....

.....

.....

.....

.....

.....

.....

.....

[3]

(b) Explain why 50 is not a perfect square number.

.....

.....

.....

[1]



17. The four vertices of parallelogram $ABCD$ lie on the sides of triangle PQR as shown in the diagram.

The sides PD , AD , BC and CR are equal.

Given that $\hat{ADC} = 50^\circ$, find the value of x .

You must show full details of how you obtained your answer.

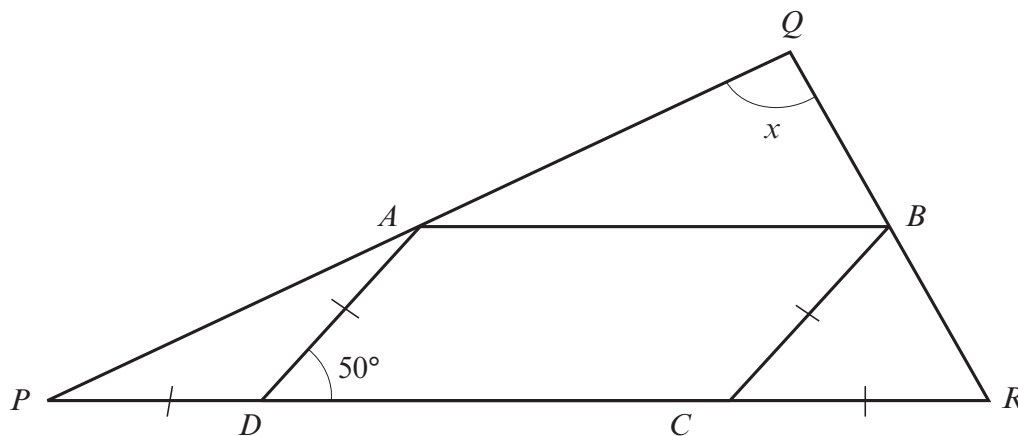

Diagram not drawn to scale

.....

.....

.....

.....

.....

.....

.....

.....

.....

.....

[6]



